

1. Introduction

Before using your Prodigy® Count-a-dose™, you should familiarize yourself with its physical characteristics and its operation.

The Prodigy® Count-a-dose™ consists of a RECTANGULAR BASE which holds the syringe and a T-SHAPED BAR which holds the insulin vials.

Lay the base of the Prodigy® Count-a-dose™ on a table in front of you. In one of the corners there is a rounded, raised area. Place this rounded, raised area in the lower left corner. This raised area has a round side and a **flat side**. The **flat side** is where the plunger of the syringe will be seated. Along the left side of the base is a channel. The barrel and flanges of the syringe lie in this **channel**. There are **notches** to secure the flanges. Toward the upper left corner there is a **clip** that holds the barrel of the syringe in place. The upper right corner is a flat, smooth panel. Immediately below this panel is a large, raised **plus sign (+)**; below the **plus sign (+)** is a **notched click dial**; near the lower right corner is large, raised **minus sign (-)**.

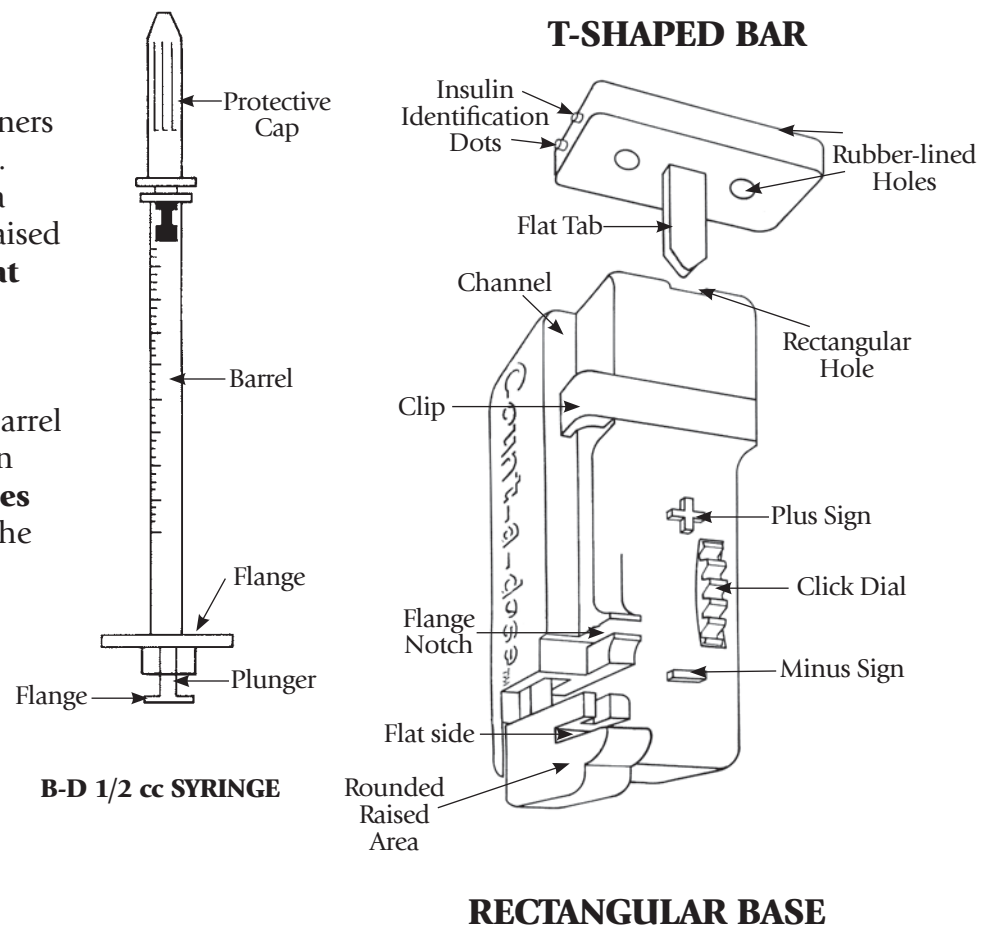

You can place the regular insulin on the end with one dot and the suspension insulin on the end with two dots.

Insulin vials can be further identified by placing a rubber band or piece of tape on the Regular insulin vial. Braille markings can be used to indicate the type of insulin contained in a vial and the expected date when this insulin vial will be empty.

2. Positioning the Syringe

1. The syringe fits into the **channel** on the left side of the Prodigy® Count-a-dose™ base. To place the syringe in the **channel**, you must remove the plastic cap covering the plunger. Do not remove the long narrow cap protecting the needle at this time.
2. Push the plunger of the syringe in as far as it will go. If the plunger is out even a fraction, the syringe will not seat properly.
3. Also make sure the **click dial** on the Prodigy® Count-a-dose™ is turned completely toward the **minus sign (-)**. If it is not rotated as far as it will go, the syringe will not seat properly.

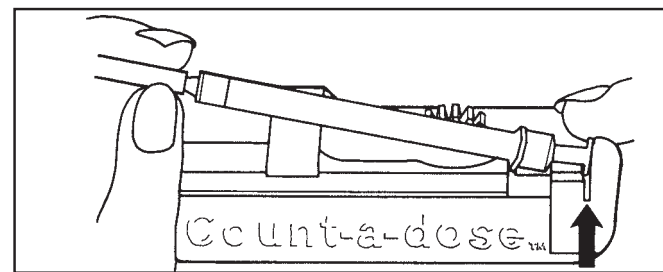

4. Place the plunger against the flat side of the raised area as shown above. The flanges will seat in their notches properly only if they are lying horizontally. Slip the barrel of the syringe under the clip into the channel as shown below.

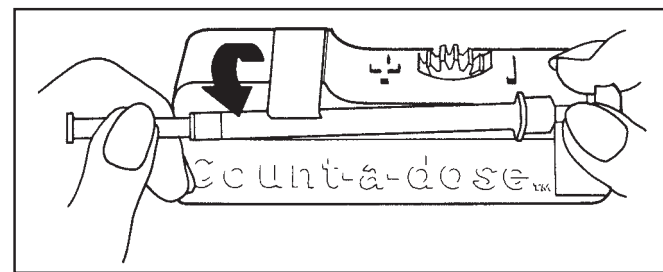

You may find it easier to reverse the procedure for positioning the syringe. This means you would place the barrel of the syringe under the clip, and then grasp

the flanges and the plunger placing the plunger against the flat side of the raised area.

5. The syringe fits loosely under the **clip** and the flanges on the syringe can be rocked from side to side.
6. To be certain that your syringe is properly seated in the **channel**, place your thumb on the **click dial** and move the dial a number of clicks toward the **plus sign (+)**. If the bracket is drawing the plunger out of the syringe, the syringe is seated properly.

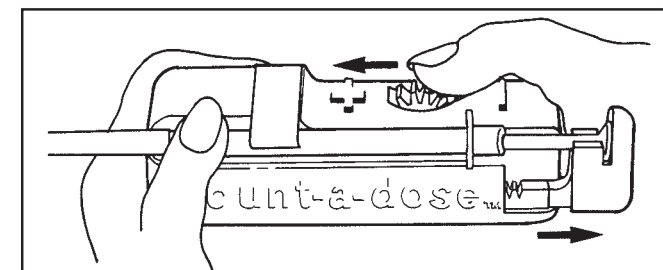

7. Move the click dial all the way down toward the **minus sign (-)**. This will push the plunger back up into the barrel of the syringe.
8. Set the rectangular base of the Prodigy® Count-a-dose™ aside.

NOTE: You will need to pressurize or inject air into your insulin vials to replace the insulin that you take out. A procedure for pressurizing your insulin vials using the Prodigy® Count-a-dose™ is described at the end of these instructions.

3. Installing Insulin Vials on the T-BAR

1. Place the top of the regular insulin vial in the **rubber-lined hole** of the T-BAR on the **single dot**.

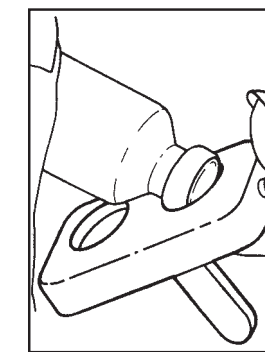

2. If you are using a suspension insulin, roll the vial gently between your palms, mixing the cloudy material evenly through the solution. Now mount the top of the vial of the suspension insulin in the other **rubber-lined hole** on the end with **two dots**.

3. Turn the T-BAR upside down placing the bottom of the insulin vials on the table.

4. Press down on the T-BAR to be sure the vials are securely mounted. Even when properly mounted, the vials can be wiggled from side to side.

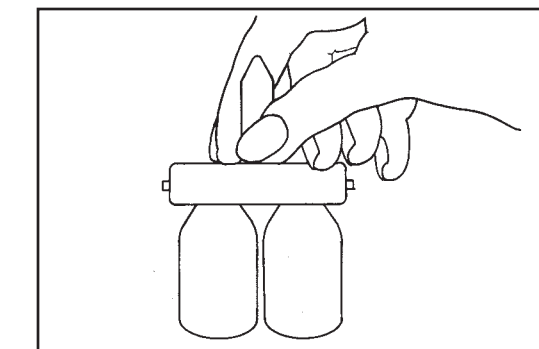

NOTE: For daily use, you do not need to remove the suspension insulin vial to mix it. Simply roll the T-BAR between your palms or rock it gently from side to side.

4. Cleaning the Insulin Vials

1. The rubber stoppers on the tops of your insulin vials must be cleaned before you insert the needle.
2. Place the bottoms of the insulin vials on the table with the **tab** of the T-BAR pointing up.
3. Examine the surface of the T-BAR on both sides of the tab. There are **two small holes**, one on each side of the **tab**.
4. You must swab in and around the holes with an alcohol swab to clean the rubber stoppers on the top of the insulin vials.

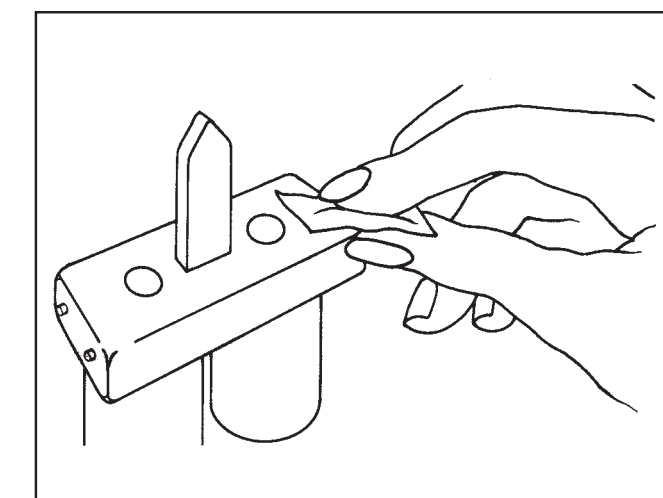

5. Set the T-BAR with mounted insulin vials aside.

This product is guaranteed to perform satisfactorily for a period of one year. If for any reason your Prodigy® Count-a-dose™ fails to operate properly, return it with the original box and a copy of your sales slip to Prodigy Diabetes Care, LLC for a free replacement.

5. Mounting the T-BAR on the RECTANGULAR BASE

1. Return to the RECTANGULAR BASE of the Prodigy® Count-a-dose™. Place the palm of your hand on the front and use your thumb or index finger to locate the rectangular hole on the top.

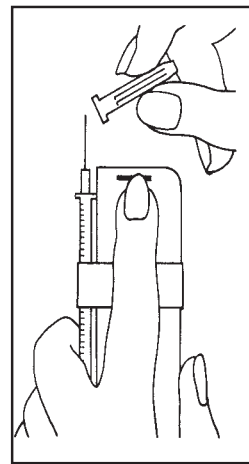
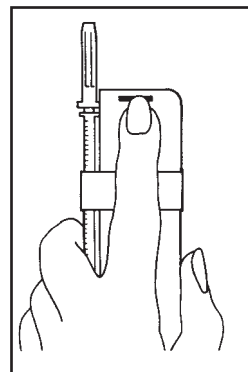

2. Now, remove the protective cap covering the needle. Remember, the syringe fits loosely in the Prodigy® Count-a-dose™, so you must keep your hand around it, holding the syringe firmly in place.

3. Hold the Prodigy® Count-a-dose™ pointing the needle of the syringe toward the ceiling.

4. Pick up the T-BAR and turn the insulin vials upside down so the bottoms of the vials are pointed upward.

5. Position the T-BAR so the type of insulin you intend to draw first is on the left side, above the needle.

6. The T-BAR **must** fit into the **rectangular hole**. Use the tab of the T-BAR to locate your extended finger and guide the tab into the **rectangular hole**.

As the tab is being inserted, the needle will penetrate the rubber stopper of the insulin vial. (The needle should slide easily into the vial. If you encounter resistance, such as ticking of the needle against plastic, gently lift the T-BAR, realigning it, and again slide the tab into the **rectangular hole**.)

This technique eliminates the possibility of damage to, or contamination of, the needle).

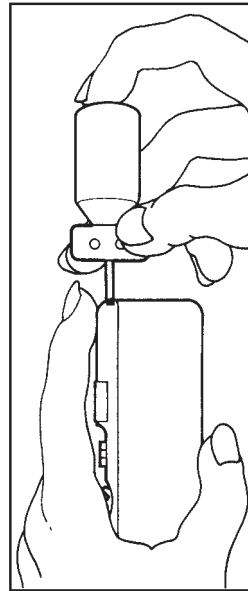

NOTE: The RECTANGULAR BASE of the Prodigy® Count-a-dose™ and the T-BAR guide are positioned so that when the needle is inserted into the rubber stopper, all but a very small amount of insulin can be drawn from the vial.

CAUTION:

Syringe batches may vary, causing minor dosage discrepancies when used with Prodigy® Count-a-dose™. To date, reported discrepancies have not exceeded 1 unit, greater or lesser than the desired insulin dose and have usually been lesser. If up to a 1-unit discrepancy might significantly affect your diabetes control, please discuss the matter immediately with your physician or diabetes educator. Additionally, we recommend that a sighted person verify the accuracy and/or discrepancy of dosage whenever you begin to use a new batch of syringes. Should you have any questions or concerns, please call us at 1.800.243.2636 for technical support.

6. Drawing a Dose of Insulin

1. It is absolutely necessary that the bottom of the insulin vial(s) be pointed straight up toward the ceiling when air bubbles are being removed from the syringe or when insulin is being drawn with the Prodigy® Count-a-dose™.

2. Eliminate air bubbles in the syringe by drawing some insulin into the syringe and then ejecting it back into the vial. To do this, move the dial a few clicks toward the raised **plus sign (+)**, then move the dial all the way down to the raised **minus sign (-)**. Repeat this procedure 2 or 3 times in succession to clear the syringe of any air bubbles.

NOTE: The following instructions are an example of a dose of insulin and do not apply specifically to your insulin requirements.

3. If you would like to measure 10 units of regular insulin and 15 units of suspension insulin, you would usually begin by measuring the regular insulin. (If you are measuring suspension insulin first there is no need to change your procedure in order to use the Prodigy® Count-a-dose™).

4. The dial of the count-a-dose should be rolled all the way down toward the **minus sign (-)**.

5. With the regular insulin placed on the left (or syringe) side, move the dial 10 clicks toward the **plus sign (+)**. Each click of the dial toward the **plus sign (+)** will draw 1 unit of insulin into the syringe.

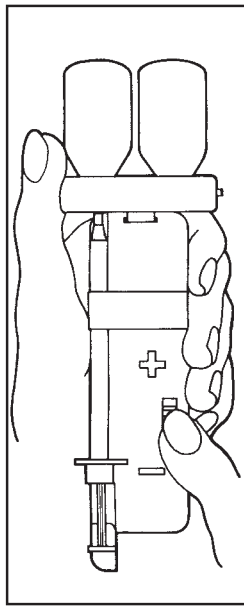

6. To add the suspension insulin into the same syringe, switch the vials by lifting the T-BAR off the base of the Prodigy® Count-a-dose™, rotate the T-BAR 180 degrees and insert the tab back into the **rectangular hole**. The suspension insulin vial will then slip over the needle of the syringe.

7. There should be no air bubbles in your syringe if you followed previously described procedure (#2 above), so do not attempt to clear air bubbles from the syringe once you have moved to the second bottle. **Do not move the dial toward the minus sign (-)**. This will contaminate your second vial of insulin with liquid from the first vial.

8. Move the dial toward the **plus sign (+)**; one click for every unit of insulin. For 15 units of suspension insulin, move the dial 15 clicks toward the **plus sign (+)**. You have now measured a total of 25 units of insulin, 10 units of regular insulin and 15 units of suspension insulin.

9. Remove the T-BAR and set it aside. Insert your finger gently under the syringe **plunger** to unseat it from the slot. Grasp the syringe by the **flanges** or the **barrel** and rotate it out from under the **clip**. Do not allow the needle to slide under the clip where it might be contaminated.

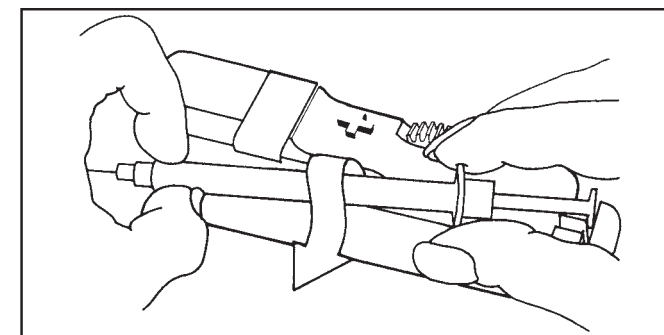

10. Return the **bracket** to zero by moving the dial back to the **minus sign (-)**. The bracket is very flexible and could be dislodged or bent if returned by pushing with the palm of your hand.

NOTE: If you are using only one type of insulin, the procedures are similar to what has just been described. Follow the instructions for Drawing a Dose of Insulin; steps 1 through 5 and steps 9 and 10 (omit steps 6 through 8).

Pressurizing Insulin Vials

1. After you have mounted your syringe in the Prodigy® Count-a-dose™, move the **click dial** as far as it will go toward the **plus sign (+)**. This will draw 50 units of air into the syringe.

2. Clean the top of your insulin vials mounted in the T-BAR with an alcohol swab.

3. Remove the **protective cap** covering the needle of your syringe.

4. Mount the T-BAR on the RECTANGULAR BASE of the Prodigy® Count-a-dose™.

5. Move the **click dial** as far as it will go toward the **minus sign (-)**. This will inject 50 units of air into your insulin vial. Repeat this procedure on your second insulin vial if you use two types of insulin.

6. Use this procedure to pressurize your insulin vials whenever necessary.

If you would like information about blindness and diabetes, contact **The National Federation of the Blind:**
1800 Johnson Street • Baltimore, MD 21230
410.659.9314 • www.nfb.org/diabetes.htm.

+ - PRODIGY®
Count-a-dose™

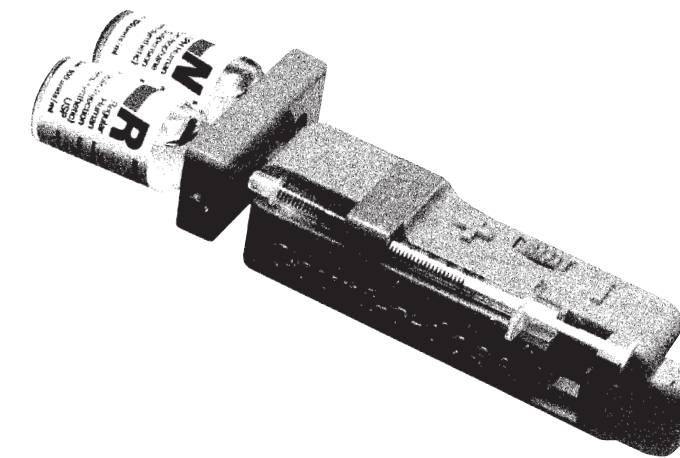

These are instructions for operating your single increment (lo-dose) Prodigy® Count-a-dose™. If you have difficulty understanding these instructions, you should seek assistance from someone knowledgeable about the Prodigy® Count-a-dose™, blindness and diabetes.

The Prodigy® Count-a-dose™ is a simple system to learn, is well-adapted to the use of non-sighted alternative techniques and allows a blind diabetic to measure from one to fifty units of insulin in single unit increments. The Prodigy® Count-a-dose™ uses a BD (Becton Dickinson) lo-dose syringe, a 50-unit (1/2 cc) insulin syringe or a Prodigy® 50-unit (1/2 cc) syringe.

Manufactured by:
Prodigy Diabetes Care, LLC
P.O. Box 481928
Charlotte, NC 28269 USA
1.800.243.2636
www.prodigymeter.com